



## TVC-BIR-MR

TruVision Cam IR Bullet Mid-Res Camera, 480 TVL Color, 3.5–12 mm Varifocal, 25m

### Overview

The TruVision™ line from GE Security includes a comprehensive family of infrared (IR) cameras for standalone or basic integrated installations that are flexible and scalable to accommodate future growth. Ideal for surveillance system installations ranging from convenience stores to retail mall parking lots, the TruVision IR line has the right cameras for your job and can help you stay within budget constraints without compromising security needs.

These flexible cameras can see in total darkness, providing color images by day and black-and-white images under IR operation in low-light applications. Form factors include omni-directional dome and traditional bullet cameras. Dome models allow for ceiling or wall mounting while still maintaining a level field of view. Single gang adaptor plates are included with the MR and HR dome models, while the bullet models offer a familiar form factor that can also be ceiling or wall mounted. TruVision IR dome and bullet cameras are also available in fixed lens and varifocal lens models.

### Application

Built for long-lasting service and plug-and-play functionality, the TruVision IR line provides a valuebased solution that is ideal for applications ranging from residential to office buildings.

Designed for low-light and complete-darkness environments, TruVision cameras' balanced IR capabilities and multiple resolution options offer the perfect camera for each situation. With weather-resistant options that are well suited for indoor and outdoor applications, TruVision cameras represent sensible, secure video surveillance you can depend on.



### Standard Features

- **Balanced IR illumination for optimal viewing in low- to no-light environments**
- **provide flexible installation options and ensure the right camera for the job**
- **Compatible with all analog CCTV recording devices and equipment**
- **IP67 ratings for weather-resistant performance**
- **480 TV lines**
- **IR Range of 25 m**
- **24VAC/12VDC**

# TVC-BIR-MR

TruVision Cam IR Bullet Mid-Res Camera, 480 TVL Color, 3.5–12 mm Varifocal, 25m

## Specifications

### Camera

- Pick-up device: 1/3" Interline transfer CCD
- Total pixels: NTSC: 811(H) x 508(V)  
PAL: 795(H) x 596(V)
- Effective pixels: NTSC: 768(H) x 494(V)  
PAL: 752(H) x 582(V)
- Resolution: 480 TV lines
- Sync. system: 2.1 internal
- Scanning system: NTSC 525 Lines/30 Fields  
PAL 625 Lines/50 Fields
- S/N ratio: More than 48dB (AGC OFF)
- Electronic shutter: Auto 1/60 (1/50)- 1/100,000 sec.
- Min. illumination: 0.3 lux color / F2.0; 0.00 lux IR ON
- Video output: Composite 1.0 Vp-p / 75 ohm
- IR distance: 82 ft./25 m (20 pcs IR LED)
- IR trigger: 2.6 lux/2.7 lux IR ON/OFF
- Lens type: Varifocal lens: 3.5 - 12 mm

### Electrical

- Power source: 24 VAC / 12VDC
- Power consumption: 10W (Max)
- Current: 12VDC: 250mA (IR OFF)  
12VDC: 740mA (Max)  
24VAC: 290mA (IR OFF)  
24VAC: 650mA (Max)

### Environmental & Physical

- Weight: 26 oz./ 0.76 kg
- Dimensions: 2.99 in. (W) x 3.27 in. (H) x 6.14 in. (D)  
(76 mm x 83 mm x 156 mm)
- Operation temperature: -10 to 50° C (14 to 122° F)
- Storage temperature: -20 to 70° C (-4 to 158° F)
- Weather resistant: IP67

## Diagram

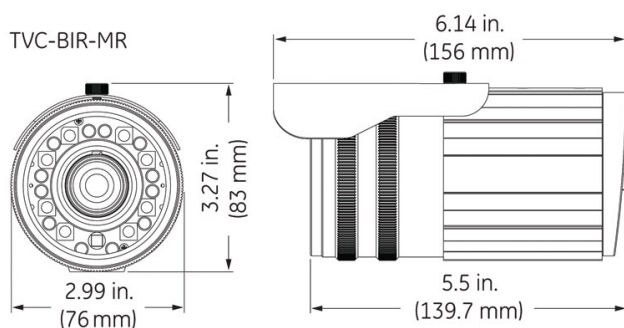

## Ordering Information

### TVC-BIR-HR

TruVision Cam IR Bullet High-Res Camera, 530 TVL Color, 6.0–50.0 mm Varifocal Lens, 180.4 ft./55 m IR Range, 24VAC/12VDC, NTSC

### TVC-BIR-MR

TruVision Cam IR Bullet Mid-Res Camera, 480 TVL Color, 3.5–12 mm Varifocal Lens, 82 ft./25 m IR Range, 24VAC/12VDC, NTSC

### TVD-TIR-HR

TruVision Dome IR High-Res Camera, 530 TVL Color, 3.5–8.0 mm Varifocal Lens, 65.6 ft./20 m IR Range, 12VDC only, NTSC

### TVD-TIR-MR

TruVision Dome IR Mid-Res Camera, 480 TVL Color, 3.5–8.0 mm Varifocal Lens, 65.6 ft./20 m IR Range, 12VDC only, NTSC

### TVD-TIR-SR

TruVision Dome IR Standard-Res Camera, 380 TVL Color, 4.3 mm Fixed Lens, 32.8 ft./10 m IR Range, 12VDC only, NTSC