

ROTATING BEACON EExd, Weatherproof TH12 Range



Introduction

These certified rotating beacons have been designed for use in potentially explosive atmospheres and harsh environmental conditions. The enclosures are suitable for use offshore or onshore, where light weight combined with corrosion resistance is required.

The housing is manufactured completely from a U.V. stable, glass reinforced polyester. Stainless steel screws and mounting bracket are available ensuring a totally corrosion free product.

Units can be painted to customer specification and supplied with identification labels.

- ★ Zone 1 and Zone 2 use.
- ★ EExd, IIB T4 and T5.
- ★ ATEX approved, Ex II 2G.
- ★ BASEEFA Certified.
- ★ GOST 'R' Certified.
- ★ Inmetro Certified.
- ★ IP66 and IP67.
- ★ Certified temperature -55°C to $+70^{\circ}\text{C}$.
- ★ 55W and 70W tungsten halogen bulb*.
- ★ Various rotating speeds available.
- ★ Corrosion resistant GRP.
- ★ Optional stainless steel backstrap.
- ★ Various lens colours.
- ★ Optional lens guard.

* Voltage dependent.

Distribuidor autorizado: www.tucanobrasil.com.br

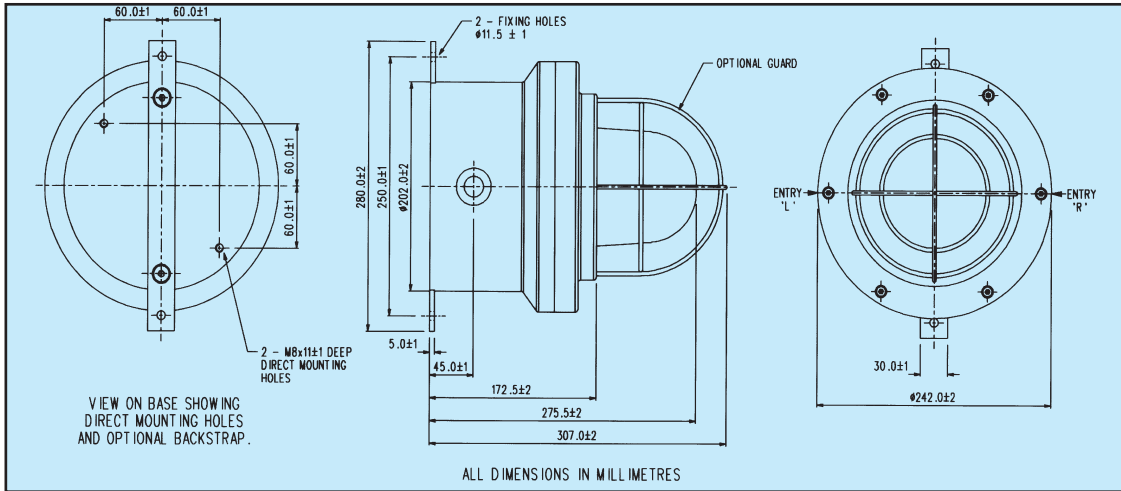

Specification

Certification:	CENELEC 50015, 50018, 50019. Certification No. BAS99ATEX2196. EExd IIB T4 & T5. GOST 'R' Certified: 1Exd IIB T4/T5. Inmetro Certified: B R-Ex d IIB T3/T4/T5/T6.
Material:	Body: – Glass reinforced polyester (GRP). Lens: – Glass Cover screws and backstrap: – stainless steel 316.
Finish:	Natural black or painted to customer specification.
Weight:	7.6kg.
Certified Temperature:	-55°C to +70°C (T4), -55°C to +40°C (T5).
Ingress Protection:	IP66 & IP67.
Fire Retardancy:	GRP is fire retardant to ISO 1210.
Earth Continuity:	Optional for metal glands provided via a brass plate.
Terminals:	6 x 6.0mm ² .
Labels:	Tag/duty label option.
Entries:	2 x M20 ISO.
Life:	We do not recommend the continuous use of the TH12 for over 3 hours as this could adversely affect its life.
Bulb Type:	70 Watt H1 tungsten halogen bulb (24V). 55 Watt H1 tungsten halogen bulb (12V).

Wattage	55W	70W	70W	70W
Voltage	12 d.c	24 d.c.	110 a.c.	240 a.c
Peak Current	4.85A	2.92A	0.64A	0.34A

Rotational Speed (r.p.m.)	60	120	180
Effective Intensity (Cd)	3354	1957	895
Peak Intensity (Cd)	11164	11164	11164

Note: The above figures (Cd) are for a 70W lamp with clear lens. Rotational speed may vary by ±20% of the stated r.p.m.

For coloured lenses

Colour	Red	Blue	Amber	Green	Yellow
Multiplying Factor	0.15	0.12	0.51	0.49	0.86

The photometric data has been verified by BSI, a report of which is available if required.

Ordering Requirements

The following code is designed to help in the selection of the correct unit. Build up the reference number by inserting the code for each component into the appropriate box. **For standard products, available ex-stock, contact sales office for details.**

Model	Certification	Speed	Voltage	Lens Colour	Lens Guard	Unit Fixing	Options	Unit Finish																																																																																						
TH12	<input type="text"/>	<input type="text"/>	<input type="text"/>	<input type="text"/>	<input type="text"/>	<input type="text"/>	<input type="text"/>	<input type="text"/>																																																																																						
	<table border="1"> <tr><th colspan="2">Certification Code</th></tr> <tr><td>ATEX</td><td>B</td></tr> <tr><td>GOST 'R'</td><td>G</td></tr> <tr><td>Inmetro</td><td>DM</td></tr> </table>	Certification Code		ATEX	B	GOST 'R'	G	Inmetro	DM	<table border="1"> <tr><th colspan="2">Speed Code</th></tr> <tr><td>60 r.p.m.</td><td>A</td></tr> <tr><td>120 r.p.m.</td><td>B</td></tr> <tr><td>180 r.p.m.*</td><td>C</td></tr> <tr><td colspan="2">*Not available 110V a.c.</td></tr> </table>	Speed Code		60 r.p.m.	A	120 r.p.m.	B	180 r.p.m.*	C	*Not available 110V a.c.		<table border="1"> <tr><th colspan="2">Voltage Code</th></tr> <tr><td>12V d.c.*</td><td>012</td></tr> <tr><td>24V d.c.†</td><td>024</td></tr> <tr><td>110V a.c.†</td><td>110</td></tr> <tr><td>240V a.c.†</td><td>240</td></tr> <tr><td colspan="2">*55W only available 12V d.c.</td></tr> <tr><td colspan="2">†70W only available 24V d.c., 110V a.c. & 240V a.c.</td></tr> </table>	Voltage Code		12V d.c.*	012	24V d.c.†	024	110V a.c.†	110	240V a.c.†	240	*55W only available 12V d.c.		†70W only available 24V d.c., 110V a.c. & 240V a.c.		<table border="1"> <tr><th colspan="2">Colour Code</th></tr> <tr><td>Red</td><td>R</td></tr> <tr><td>Blue</td><td>B</td></tr> <tr><td>Green</td><td>G</td></tr> <tr><td>Amber</td><td>A</td></tr> <tr><td>Yellow</td><td>Y</td></tr> <tr><td>Clear</td><td>C</td></tr> </table>	Colour Code		Red	R	Blue	B	Green	G	Amber	A	Yellow	Y	Clear	C	<table border="1"> <tr><th colspan="2">Guard Code</th></tr> <tr><td>None</td><td>N</td></tr> <tr><td>Yes</td><td>Y</td></tr> </table>	Guard Code		None	N	Yes	Y	<table border="1"> <tr><th colspan="2">Unit Fixing Code</th></tr> <tr><td>Direct Mounting</td><td>D</td></tr> <tr><td>Backstrap</td><td>B</td></tr> </table>	Unit Fixing Code		Direct Mounting	D	Backstrap	B	<table border="1"> <tr><th colspan="2">Options Code</th></tr> <tr><td>Tag Label</td><td>T*</td></tr> <tr><td>Duty Label</td><td>D*</td></tr> <tr><td>Earth Continuity</td><td>E</td></tr> <tr><td>None</td><td>N</td></tr> <tr><td colspan="2">*Please specify wording</td></tr> </table>	Options Code		Tag Label	T*	Duty Label	D*	Earth Continuity	E	None	N	*Please specify wording		<table border="1"> <tr><th colspan="2">Finish Code</th></tr> <tr><td>Natural Black</td><td>N</td></tr> <tr><td>Red</td><td>R</td></tr> <tr><td>Blue</td><td>B</td></tr> <tr><td>Yellow</td><td>Y</td></tr> <tr><td>Grey</td><td>G</td></tr> <tr><td>White</td><td>W</td></tr> <tr><td>Special Finish</td><td>S</td></tr> </table>	Finish Code		Natural Black	N	Red	R	Blue	B	Yellow	Y	Grey	G	White	W	Special Finish	S
Certification Code																																																																																														
ATEX	B																																																																																													
GOST 'R'	G																																																																																													
Inmetro	DM																																																																																													
Speed Code																																																																																														
60 r.p.m.	A																																																																																													
120 r.p.m.	B																																																																																													
180 r.p.m.*	C																																																																																													
*Not available 110V a.c.																																																																																														
Voltage Code																																																																																														
12V d.c.*	012																																																																																													
24V d.c.†	024																																																																																													
110V a.c.†	110																																																																																													
240V a.c.†	240																																																																																													
*55W only available 12V d.c.																																																																																														
†70W only available 24V d.c., 110V a.c. & 240V a.c.																																																																																														
Colour Code																																																																																														
Red	R																																																																																													
Blue	B																																																																																													
Green	G																																																																																													
Amber	A																																																																																													
Yellow	Y																																																																																													
Clear	C																																																																																													
Guard Code																																																																																														
None	N																																																																																													
Yes	Y																																																																																													
Unit Fixing Code																																																																																														
Direct Mounting	D																																																																																													
Backstrap	B																																																																																													
Options Code																																																																																														
Tag Label	T*																																																																																													
Duty Label	D*																																																																																													
Earth Continuity	E																																																																																													
None	N																																																																																													
*Please specify wording																																																																																														
Finish Code																																																																																														
Natural Black	N																																																																																													
Red	R																																																																																													
Blue	B																																																																																													
Yellow	Y																																																																																													
Grey	G																																																																																													
White	W																																																																																													
Special Finish	S																																																																																													