

# 21 JOULE XENON BEACONS

## Exd(e), Weatherproof

### XB4 Range



## Introduction

These **high output (21 Joule)** beacons have been designed for use in potentially explosive atmospheres and harsh environmental conditions. The marine grade alloy or stainless steel enclosures are suitable for use offshore or onshore, where light weight combined with corrosion resistance and strength is required. Units can be painted to customer specification and fitted with identification labels.

Available with optional Exe terminal chamber.

- ★ Zone 1 and Zone 2 use.
  - ★ Exde IICT5.
  - ★ ATEX approved Ex II 2GD.
  - ★ BASEEFA certified.
  - ★ UL Listed for USA and Canada
    - Hazardous locations:
      - Class I, Div 1, Groups C & D.
      - Class I, Zone 1, AExd IIB T4.
    - Ordinary locations: Visual-Signal Device.
  - ★ GOST 'R' Certified.
  - ★ Brazilian (Inmetro) Certified.
  - ★ Australian (SAA) certified.
  - ★ \*Certified temperature  $-55^{\circ}\text{C}$  to  $+70^{\circ}\text{C}$ .
  - ★ IP67 and IP66.
  - ★ Stainless steel or marine grade alloy.
  - ★ Various lens colours.
  - ★ Twin replaceable tubes.
  - ★ Exde version has gland earth continuity in the GRP terminal chamber.
  - ★ Tapered spigot flame path.
  - ★ Telephone or relay initiated option.
  - ★ Optional lens guard.
- \*Depending on version.

# Specification

Voltage	DC			AC 50/60 Hz				
	24	48	110	110	120	220	240	254
Tube Energy (Joules)	21	21	21	21	21	21	21	21
Peak Current Consumption (mA)	1400	540	240	350	450	240	185	210
Effective Intensity (Cd)	355	355	355	355	355	355	355	355
Peak Intensity (Cd)	123691	123691	123691	123691	123691	123691	123691	123691

NOTE: The above figures (Cd) are for a clear lens @ 1Hz flash rate.

The photometric data has been verified by BSI. A report is available if required.

FOR COLOURED LENSES

Colour	Red	Blue	Amber	Green	Yellow
Multiplying Factor (Approximate)	0.15	0.12	0.51	0.49	0.86

Telephone initiation or relay interface:

Initiation by telephone ringing tone or low voltage control signals, plus initiation of a second beacon or sounder.

Certification: CENELEC EN60079-0:2006, EN60079-1:2004  
EN60079-7:2007, EN61241-0:2006, EN61241-1:2004  
Certification Baseefa02ATEX0224X.  
ATEX Exd IIC T5 or Exde IIC T5.

**UL Listed for USA and Canada**

- Hazardous locations:  
Class I, Div 1 Groups C-D  
Class I, Zone 1.

Listing No. E187894.

- Ordinary locations: Visual-Signal Device.

Listing No. S8128.

Refer to UL data sheet at rear of catalogue for complete information.

**GOST 'R' Certification:** 1 Exd IIC T4, Russian Fire Approved (VNIIPO).

**Australian Certification:** Contact MEDC for specification.

**Brazilian (Inmetro) Certification:** BR-Ex d IIC T3/T4/T5/T6.

BR-Ex de IIC T3/T4/T5/T6.

Certified Temperature:

UL -25°C to +70°C BASEEFA & GOST-50°C to +55°C (Exde).  
-55°C to +55°C (Exd).

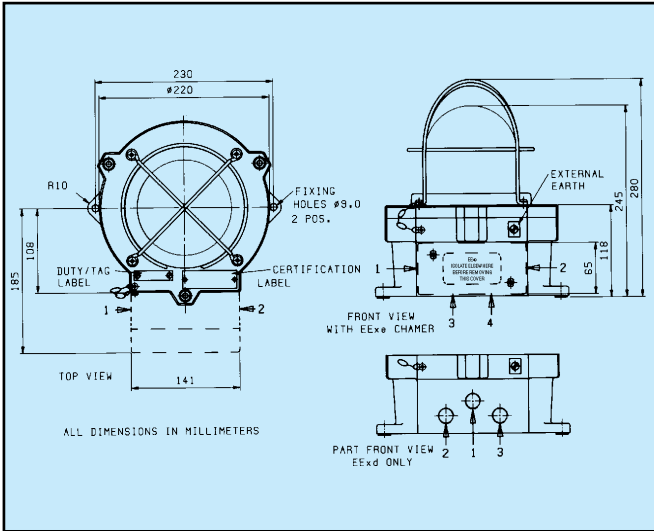

Terminals:	Exe: 6 off suitable for up to 6mm <sup>2</sup> cable. (With telephone initiate 10 x 2.5mm <sup>2</sup> ). Exd: 8 off suitable for up to 10mm <sup>2</sup> cable.
Entries:	Up to 3 x 20mm or 2 x 25mm ISO in Exd unit. Up to 4 x 20mm or 4 x 25mm ISO in Exe unit.
Materials:	LM25TF Marine Grade Alloy body. Grade 316 ANC4B Stainless Steel body. Glass reinforced polyester (GRP) terminal chamber. Toughened Wellglass.
Weights:	Exd: 6.6kg. xde: 7.6kg. Add 8.4kg for stainless steel version.
Finish:	Red epoxy paint finish as standard or to customer's specification.

## Ordering Requirements

The following code is designed to help in the selection of the correct unit. Build up the reference number by inserting the code for each component into the appropriate box. **For standard products, available ex-stock, contact sales office for details.**

Type	Certification	Voltage	Terminals	Cable Entries	Flash Rate	Initiate Options	Lens Guard	Lens Colour	Tag/Duty Label	Material	Finish																																																																												
<b>XB4</b>																																																																																							
<table border="1"> <thead> <tr> <th>Voltage</th> <th>Code</th> </tr> </thead> <tbody> <tr><td>24VDC</td><td>B</td></tr> <tr><td>48VDC</td><td>C</td></tr> <tr><td>110VDC</td><td>D</td></tr> <tr><td>110VAC</td><td>E</td></tr> <tr><td>120VAC</td><td>F</td></tr> <tr><td>220VAC</td><td>G</td></tr> <tr><td>240VAC</td><td>H</td></tr> <tr><td>254VAC</td><td>J</td></tr> </tbody> </table>		Voltage	Code	24VDC	B	48VDC	C	110VDC	D	110VAC	E	120VAC	F	220VAC	G	240VAC	H	254VAC	J	<table border="1"> <thead> <tr> <th>Entries</th> <th>Code</th> </tr> </thead> <tbody> <tr><td>20mm</td><td>*B</td></tr> <tr><td>25mm</td><td>*C</td></tr> <tr><td>1/2" NPT</td><td>*D</td></tr> <tr><td>3/4" NPT</td><td>*E</td></tr> </tbody> </table> <p>*prefix entry size (see diagram above) with entry position code e.g. 1B2B.</p>		Entries	Code	20mm	*B	25mm	*C	1/2" NPT	*D	3/4" NPT	*E	<table border="1"> <thead> <tr> <th>Flash Rate</th> <th>Code</th> </tr> </thead> <tbody> <tr><td>60/min.</td><td>06</td></tr> <tr><td>120/min.</td><td>12</td></tr> <tr><td>240/min.</td><td>24</td></tr> </tbody> </table>		Flash Rate	Code	60/min.	06	120/min.	12	240/min.	24	<table border="1"> <thead> <tr> <th>Initiate Options (XB4 only)</th> <th>Code</th> </tr> </thead> <tbody> <tr><td>None</td><td>A</td></tr> <tr><td>Telephone</td><td>B</td></tr> <tr><td>Telephone &amp; 2nd Beacon/Sounder</td><td>C</td></tr> <tr><td>*Relay (12V-48VAC/DC)</td><td>D</td></tr> <tr><td>*Relay (12V-48VAC/DC) &amp; 2nd Beacon/Sounder</td><td>E</td></tr> </tbody> </table> <p>*Specify AC/DC voltage</p>		Initiate Options (XB4 only)	Code	None	A	Telephone	B	Telephone & 2nd Beacon/Sounder	C	*Relay (12V-48VAC/DC)	D	*Relay (12V-48VAC/DC) & 2nd Beacon/Sounder	E	<table border="1"> <thead> <tr> <th>Colour</th> <th>Code</th> </tr> </thead> <tbody> <tr><td>Red</td><td>R</td></tr> <tr><td>Blue</td><td>B</td></tr> <tr><td>Green</td><td>G</td></tr> <tr><td>Yellow</td><td>Y</td></tr> <tr><td>Amber</td><td>A</td></tr> <tr><td>Clear</td><td>C</td></tr> </tbody> </table>		Colour	Code	Red	R	Blue	B	Green	G	Yellow	Y	Amber	A	Clear	C	<table border="1"> <thead> <tr> <th>Finish</th> <th>Code</th> </tr> </thead> <tbody> <tr><td>Red</td><td>R</td></tr> <tr><td>Blue</td><td>B</td></tr> <tr><td>Yellow</td><td>Y</td></tr> <tr><td>Grey</td><td>G</td></tr> <tr><td>White</td><td>W</td></tr> <tr><td>Other - specify</td><td>S</td></tr> </tbody> </table>		Finish	Code	Red	R	Blue	B	Yellow	Y	Grey	G	White	W	Other - specify	S
Voltage	Code																																																																																						
24VDC	B																																																																																						
48VDC	C																																																																																						
110VDC	D																																																																																						
110VAC	E																																																																																						
120VAC	F																																																																																						
220VAC	G																																																																																						
240VAC	H																																																																																						
254VAC	J																																																																																						
Entries	Code																																																																																						
20mm	*B																																																																																						
25mm	*C																																																																																						
1/2" NPT	*D																																																																																						
3/4" NPT	*E																																																																																						
Flash Rate	Code																																																																																						
60/min.	06																																																																																						
120/min.	12																																																																																						
240/min.	24																																																																																						
Initiate Options (XB4 only)	Code																																																																																						
None	A																																																																																						
Telephone	B																																																																																						
Telephone & 2nd Beacon/Sounder	C																																																																																						
*Relay (12V-48VAC/DC)	D																																																																																						
*Relay (12V-48VAC/DC) & 2nd Beacon/Sounder	E																																																																																						
Colour	Code																																																																																						
Red	R																																																																																						
Blue	B																																																																																						
Green	G																																																																																						
Yellow	Y																																																																																						
Amber	A																																																																																						
Clear	C																																																																																						
Finish	Code																																																																																						
Red	R																																																																																						
Blue	B																																																																																						
Yellow	Y																																																																																						
Grey	G																																																																																						
White	W																																																																																						
Other - specify	S																																																																																						
<table border="1"> <thead> <tr> <th>Certification</th> <th>Code</th> </tr> </thead> <tbody> <tr><td>ATEX</td><td>B</td></tr> <tr><td>UL</td><td>UL*</td></tr> <tr><td>UL (ordinary locations)</td><td>UW*</td></tr> <tr><td>GOST 'R' Exd</td><td>G†</td></tr> <tr><td>Inmetro</td><td>M</td></tr> </tbody> </table> <p>*UL - available alloy or stainless steel. - 24v d.c., 110v a.c., - 240v a.c. only. † - VNIIPO approved as standard.</p>		Certification	Code	ATEX	B	UL	UL*	UL (ordinary locations)	UW*	GOST 'R' Exd	G†	Inmetro	M	<table border="1"> <thead> <tr> <th>Terminals &amp; Type</th> <th>Code</th> </tr> </thead> <tbody> <tr><td>6 x 6mm<sup>2</sup> (Exe)</td><td>6E*</td></tr> <tr><td>8 x 10mm<sup>2</sup> (Exd)</td><td>8D</td></tr> </tbody> </table> <p>*UL and GOST not available Exe.</p>		Terminals & Type	Code	6 x 6mm <sup>2</sup> (Exe)	6E*	8 x 10mm <sup>2</sup> (Exd)	8D	<table border="1"> <thead> <tr> <th>Lens Guard</th> <th>Code</th> </tr> </thead> <tbody> <tr><td>None</td><td>N</td></tr> <tr><td>Yes</td><td>Y</td></tr> </tbody> </table>		Lens Guard	Code	None	N	Yes	Y	<table border="1"> <thead> <tr> <th>Duty Label</th> <th>Code</th> </tr> </thead> <tbody> <tr><td>None</td><td>N</td></tr> <tr><td>Yes</td><td>Y</td></tr> </tbody> </table> <p>(Please specify)</p>		Duty Label	Code	None	N	Yes	Y	<table border="1"> <thead> <tr> <th>Material</th> <th>Code</th> </tr> </thead> <tbody> <tr><td>Stainless steel</td><td>0</td></tr> <tr><td>Alloy</td><td>1</td></tr> </tbody> </table>		Material	Code	Stainless steel	0	Alloy	1																																										
Certification	Code																																																																																						
ATEX	B																																																																																						
UL	UL*																																																																																						
UL (ordinary locations)	UW*																																																																																						
GOST 'R' Exd	G†																																																																																						
Inmetro	M																																																																																						
Terminals & Type	Code																																																																																						
6 x 6mm <sup>2</sup> (Exe)	6E*																																																																																						
8 x 10mm <sup>2</sup> (Exd)	8D																																																																																						
Lens Guard	Code																																																																																						
None	N																																																																																						
Yes	Y																																																																																						
Duty Label	Code																																																																																						
None	N																																																																																						
Yes	Y																																																																																						
Material	Code																																																																																						
Stainless steel	0																																																																																						
Alloy	1																																																																																						