

5 JOULE XENON BEACONS

EExd, Weatherproof

XB9 Range



- ★ All GRP
- ↓
- ★ Low Initial Cost
- ↓
- ★ Greater Reliability
- ↓
- ★ Minimal Maintenance Cost
- ↓
- ★ Reduced Cost of Ownership

Introduction

These compact and lightweight beacons have been designed for use in potentially explosive atmospheres and harsh environmental conditions. The beacon housing, including the flamepaths, is manufactured completely from a UV stable glass reinforced polyester which is ideally suited for use offshore and onshore.

Stainless Steel screws and mounting bracket are incorporated ensuring a totally corrosion free unit.

Units can be painted to customer specification and supplied with identification labels.

- ★ Zone 1 and Zone 2 use.
- ★ EExd IIC T6.
- ★ ATEX Approved, Ex II 2G.
- ★ BASEEFA Certified.
- ★ Brazilian (Inmetro) Certified.
- ★ IP66 and IP67.
- ★ Certified Temperature -55°C to +55°C.
- ★ Corrosion Free GRP.
- ★ Various lens colours.
- ★ Lens guard fitted as standard.
- ★ Optional gland plus cable tail.
- ★ Stainless steel mounting bracket & screws.
- ★ Replaceable tube.

Specification

Certification: CENELEC EN50014 and EN50018.
 BASEEFA EExd II CT6 (T5).
 Cert. No. BAS00ATEX2031.
 Zone 1 and Zone 2.
 Brazilian (Inmetro) Certified: BR-Ex d IIC T5/T6

Materials: Body & Cover - Glass Reinforced Polyester (GRP).
 Lens - Toughened Glass.
 Cover Screws & Bracket - Stainless Steel 316

Finish: Natural or painted to customer requirements.

Voltage	DC			AC 50/60 Hz	
	12	24	48	110	240/254
Tube Energy (J)	5	5	5	5	5
Peak Current Consumption (A)	0.74	0.32	0.18	0.1	0.06
Effective Intensity (Cd)	29	29	29	29	29
Peak Intensity (Cd)	22213	22213	22213	22213	22213
Power Consumption (W)	9	8	9	11	15

NOTE: The above figures (Cd) are for a clear lens @ 1Hz flash rate.
 A report is available if required.

For Coloured Lenses:

Colour	Red	Blue	Amber	Green	Yellow
Multiplying Factors (Approximate)	0.15	0.12	0.51	0.49	0.86

Weight: 1.6kg.
 Certified Temperature: -55°C to +40°C(T6). -55°C to +55°C (T5).
 Ingress Protection: IP66 & IP67.
 Fire Retardancy: GRP is fire retardant to ISO 1210.
 Terminals: 3 x 2.5mm².
 Mounting: Wall mounted via bracket.
 Entries: 1 x M20 or PG 13.5.
 Optional: 1 x 3m cable tail and gland.

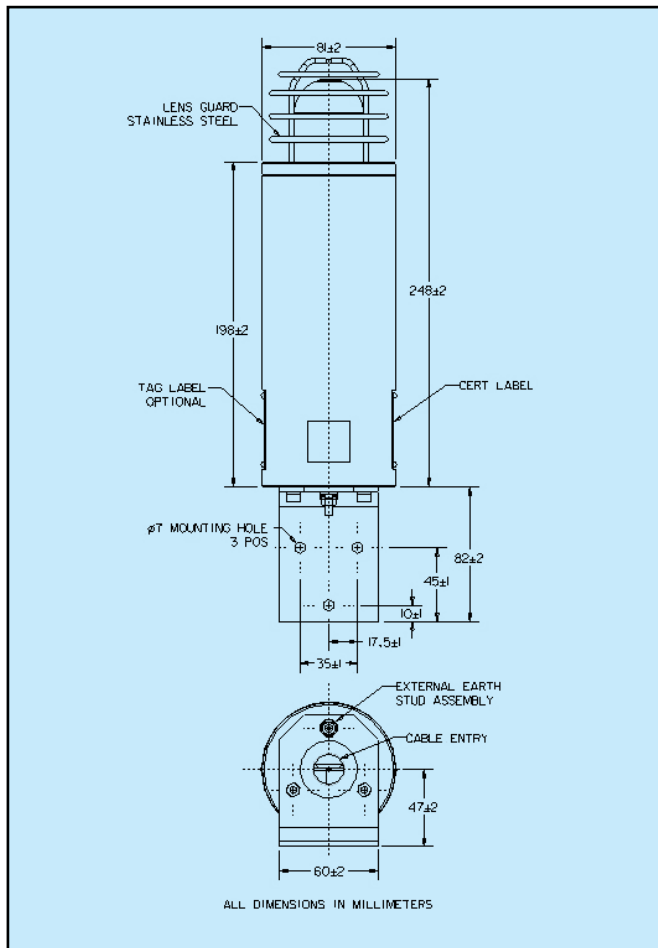

Ordering Requirements

The following code is designed to help in the selection of the correct unit. Build up the reference number by inserting the code for each component into the appropriate box. **Standard products available ex-stock as follows:**

Product	Description
XB9D02406RYNCBN	ATEX approved Ex II 2G, certified EExd IIC T6, 24v d.c., 60 flashes/min, red lens, lens guard, M20 entry + gland + 3m cable, natural black finish.
XB9D02406AYNCBN	ATEX approved Ex II 2G, certified EExd IIC T6, 24v d.c., 60 flashes/min, amber lens, lens guard, M20 entry + gland + 3m cable, natural black finish.
XB9D24006RYNCBN	ATEX approved Ex II 2G, certified EExd IIC T6, 240v a.c., 60 flashes/min, red lens, lens guard, M20 entry + gland + 3m cable, natural black finish.
XB9D24006AYNCBN	ATEX approved Ex II 2G, certified EExd IIC T6, 240v a.c., 60 flashes/min, amber lens, lens guard, M20 entry + gland + 3m cable, natural black finish.

Model	Certification	Voltage	Flash Rate	Lens Colour	Lens Guard	Tag Label	Entries/Cable Tail	Body Colour
XB9					Y			

Voltage	Code	Flash Rate	Code	Colour	Code	Tag/Duty Label	Code	Entries	Code	Finish	Code
12V d.c.	012	60/min.	06	Red	R	None	N	1 x 20mm	1B	Natural Black	N
24V d.c.	024	Other flash rates available on request, please specify.		Blue	B	*Yes	Y	1 x PG 13.5	1P	Red	R
48V d.c.	048			Green	G	*(Please specify)		Cable & Tail	CB	Blue	B
110V a.c.	110			Yellow	Y					White	W
240V a.c.	240			Amber	A					Grey	G
254V a.c.	254			Clear	C	White	W	Special Finish	S		

Certification	Code	Lens Guard	Code
Uncertified	W	Yes	Y
EExd	D		
Inmetro	DM		